

# TECHNICAL DATA

## Semco® Model 350 Gun



### Description

The Semco® model 350 sealant gun is new to the aerospace and electronics industries, although similar models have been in industrial use for many years. It is designed for quiet pneumatic application of sealants, adhesives, potting compounds and other materials packaged in Semco® disposable cartridges or Semkit® packages that are used for multi-component materials.

The Semco® model #350 gun is available with retainers to fit standard 59cc, 156cc, 214cc and 310cc (2.5, 6, 8 and 12 ounce) disposable cartridges. Air hoses to operate the gun must be ordered separately.

The gun is constructed of durable metal and engineered plastic parts designed to withstand the rigors of the production workplace. The nickel plated retainers are affixed to the gun via a quick connect, secure bayonet lock feature permitting easy cartridge replacement. A regulating wheel on the handle is used to set the working pressure at the feed volume required.

### Accessories

Hose assemblies to fit the metal air fitting are available in 1.5 meter (5 foot) increments with Hansen Aro or Schrader air fitting attached. Also available are hose assemblies equipped with a female ¼" universal fitting for air supplies that do not use the Hansen, Aro or Schrader air fittings.

PPG Aerospace provides Semco® brand precision molded cartridges, plungers, nozzles, Sem-Luer adapters and Sem-Needles. When these disposable plastic products are used in conjunction with the Semco® model 350 gun exact amounts of materials can be dispensed at the precise location required.

### Operation

Attach the air hose assembly to the compressed air source. Some applications may require the user to replace the quick release hose connector with a fitting compatible with local air supply hardware. Place the cartridge into the retainer and bayonet retainer adapter. Adjust the regulating wheel to set feed volume. When the trigger is depressed, air pressure pushes against the plunger in the cartridge. This allows for positive even dispensing of material. The material continues to flow until the trigger is released thereby permitting a drop, shot or bead to be accurately applied. The amount of material dispensed is determined by the viscosity of the material, air line pressure, regulating wheel setting, nozzle or needle orifice size and the length of time the trigger is depressed. When all the material has been dispensed from the cartridge, twist the retainer to remove from gun. Then remove the disposable cartridge and nozzle. For smooth operation weekly, add a couple drops of air tool oil in the air inlet. Dispose of leftover material in accordance with local regulations and instructions on the material safety data sheet.

### Features

- Reduces applied material cost.
- Provides accurate material control.
- Lightweight.
- 0-6.9 bar (0-100 psi) operating range.
- Available in 59cc, 156cc, 214cc and 310cc (2.5, 6, 8 and 12oz) sizes.
- Bayonet lock on retainer permits quick cartridge change.
- Durable, shock resistant parts.
- Regulating wheel adjusts the material flow.
- Positive control for smooth even dispensing.
- Ergonomic design.
- Quiet operation.

# Semco® Model 350 Gun

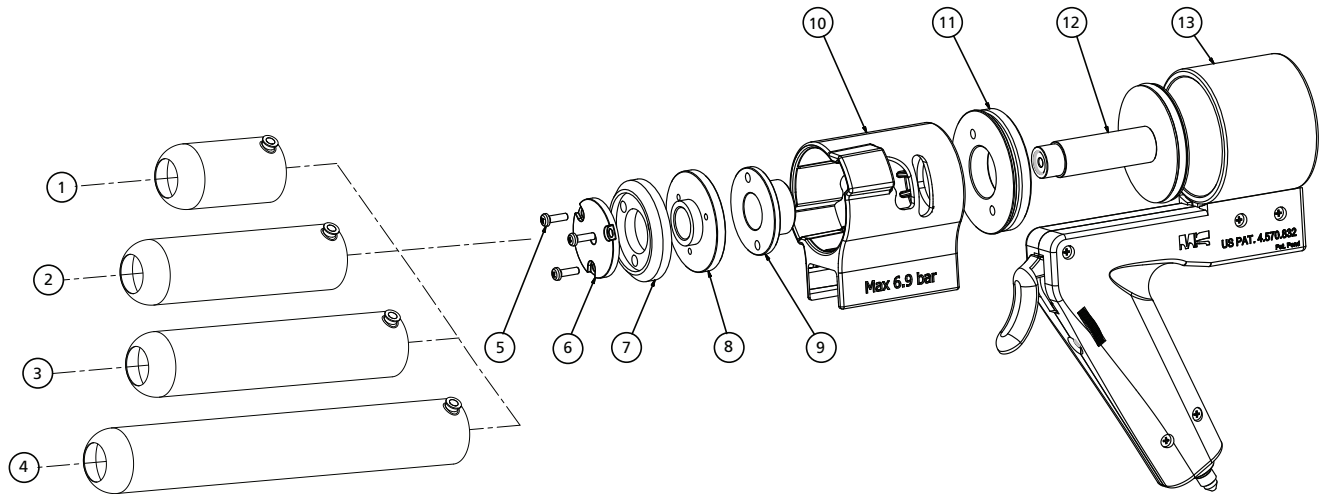

Item	Part number	Description
1	220256	Retainer, 59 cc (2.5 oz)
2	220928	Retainer, 156 cc (6 oz)
3	220926	Retainer, 214 cc (8 oz)
4	220923	Retainer, 310 cc (12 oz)
5	350001	Screw for 1608/1908
6	350002	Holding Washer for 1608
7	350003	Gasket
8		Front
9		Screw
10		Bayonet adaptor f. cartridge holder
11		Adapter holder
11		Shaft, complete
13		Handle

## Complete sealant gun (less hose)

Model no.	Part number	Size
350A	350010	No retainer
350A-2.5	350255	59 cc (2.5 oz)
350A-6	350065	156 cc (6 oz)
350A-8	350085	214 cc (8 oz)
350A-12	350125	310 cc (12 oz)

All hose assemblies must be ordered separately. Fitted hoses are available with Hansen, Aro, or Schrader connectors.

For customer assembly and repair of hoses, the following components are available.

## Components available

Description	Part no.
Hansen connector assembly	229186
Aro connector assembly	229187
Schrader connector assembly	229188
B-Nut assembly (gun end)	229189
Bulk gun hose (sold by the foot)	220895

## Hose Assemblies

Hansen	Schrader	Aro	Length
280000	280006	280012	1.5 m (5 ft)
280001	280007	280013	2.9 m (10 ft)
280002	280008	280014	4.4 m (15 ft)
280003	280009	280015	5.9 m (20 ft)
280004	280010	280016	7.3 m (25 ft)
280005	280011	280017	8.9 m (30 ft)



Complies with Machinery Directive 93/68EEC and Safety Standard EN60292

Semco and Semkit are trademarks of PRC-DeSoto International Inc., registered with the U.S. Patent Office.

All recommendations, statements, and technical data contained herein are based on tests we believe to be reliable and correct, but accuracy and completeness of said tests are not guaranteed and are not to be construed as a warranty, either expressed or implied. User shall rely on his own information and tests to determine suitability of the product for the intended use and assumes all risks and liability resulting from his use of the product. Seller's and manufacturer's sole responsibility shall be to replace that portion of the product of this manufacturer which proves to be defective. Neither seller nor manufacturer shall be liable to the buyer or any third person for any injury, loss, or damage directly or indirectly resulting from use of, or inability to use, the product. Recommendations or statements other than those contained in a written agreement signed by an officer of the manufacturer shall not be binding upon the manufacturer or seller.

Printed in the U.S.A

PRC-DeSoto International, Inc.  
12780 San Fernando Road  
Sylmar, CA 91342  
Telephone (818) 362-6711  
Toll Free (800) AEROMIX  
www.semcoPackaging.com

Issue Date: 12/10  
Supersedes: New  
Lit: 4077